

# AN-9001

CEILING MOUNT MICROPHONE

The AN-9001 is an electret condenser microphone designed for ambient noise detection. It is used in conjunction with the AN-001T Ambient Noise Sensor Input module in the 9000 Series system. It can be mounted in a 1-gang electrical box in the ceiling or wall.

---



Article number:AN-9001

---

## Specifications

Dimensions (W x H x D)	x 37
Dimensions (ø x D)	130 x 37 mm
Finish	ABS resin, Steel plate, surface-treated, white,
Operating temperature	-10°C to +40°C

# AN-9001

CEILING MOUNT MICROPHONE

Appearance

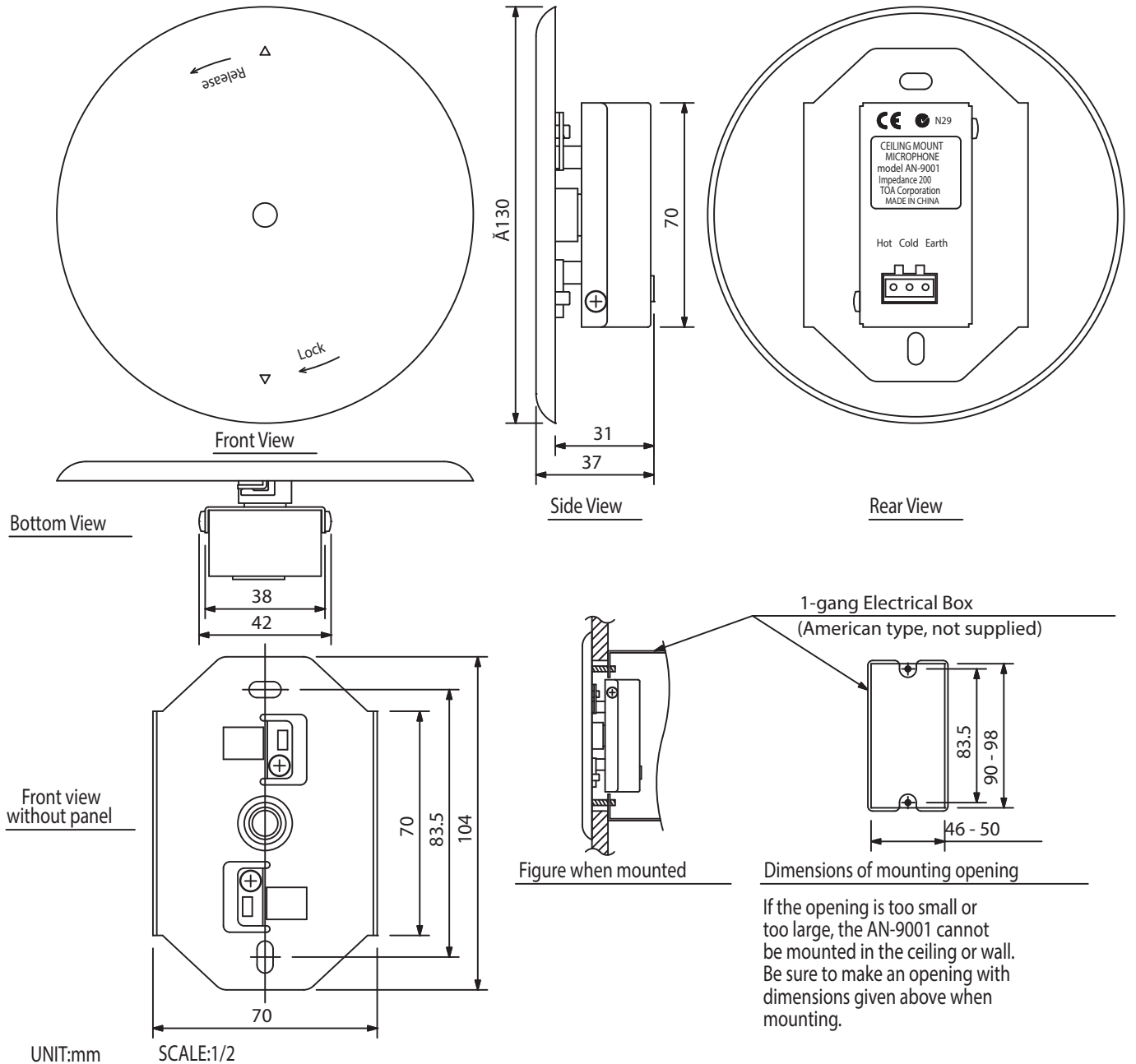

If the opening is too small or too large, the AN-9001 cannot be mounted in the ceiling or wall. Be sure to make an opening with dimensions given above when mounting.